

AMBER SELECT / AMBER SELECT^X

Wireless Emergency Response System



Visonic[®]

User's Guide

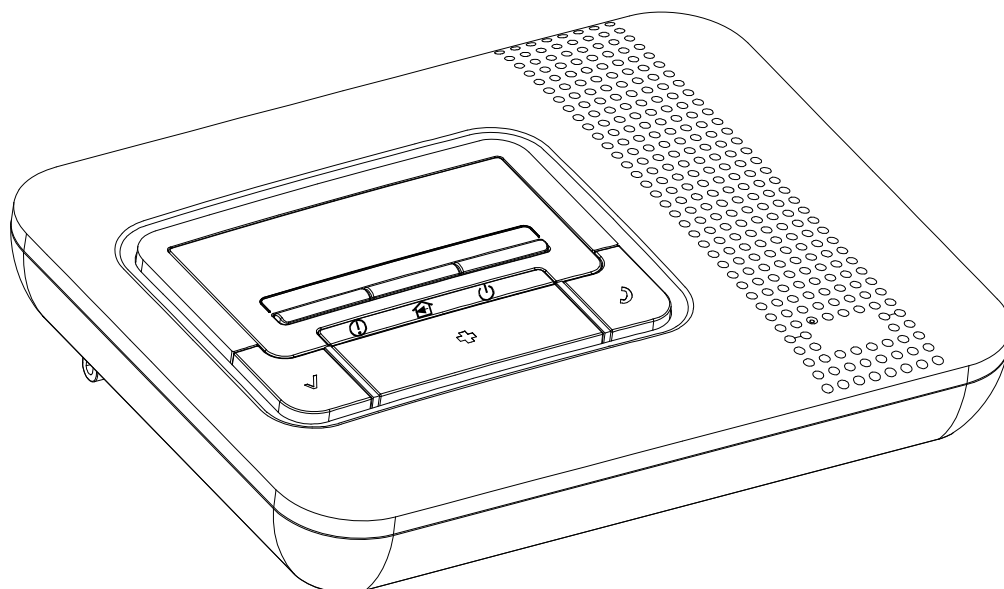

Wireless Emergency Response System

Congratulations on your purchase of the wireless AMBER SELECT / AMBER SELECT^X Personal Emergency Response system.

The AMBER SELECT^X operates the same as the AMBER SELECT but without a display.

This home health care signaling system was designed to support people in their home environment. In the event of an emergency, help can be summoned at the press of a button and that same message can be sent to private numbers that you have selected for notification. In the event of fire, the system can be programmed to automatically call the monitoring station or to private phones.

The Unit includes a large display (not applicable to AMBER SELECT^X) that shows the system status, the time and preprogrammed medication reminders.

The Unit's rechargeable backup battery can provide up to 24 hours of operation. When AC power is restored, the backup battery is automatically recharged.

What's Included

Before you begin to set up your system, make sure you have all the necessary components.

- AMBER SELECT / AMBER SELECT^X Unit
- 120VAC to 12VAC transformer type OH-48109AT, Input 120VAC 60 Hz / Output 12VAC 1000 mA
- Pendant transmitters supplied with necklace

Additional Accessories (Optional)

- Battery operated smoke detector (MCT-425)
- Waterproof arm/disarm security activation pendant transmitter (MCT-201 WP)
- Fully supervised indoor, PowerCode, gas detectors (MCT-440, MCT-441) and carbon monoxide gas detector (MCT-442)
- Fully supervised indoor, PowerCode, flood detector (MCT-550)
- Fall detector pendant transmitter (MCT-241MD), supplied with clip (to be attached to the user belt or shirt pocket)
- Wristband supplied for (MCT-212)
- Pet-Immune PowerCode wireless PIR motion detector (NEXT K9-85)
- Supervised PowerCode magnetic contact transmitter (MCT-302)
- Microprocessor controlled wireless repeater (MCX-600)

The system unit is shown in Figure 1.

Note: All of the listed transmitters have a PERS suffix. In addition, the "txid" code of each transmitter is printed on the packaging.

Note: PowerCode refers to Visonic's proprietary communications protocol which makes use of unique ID codes.

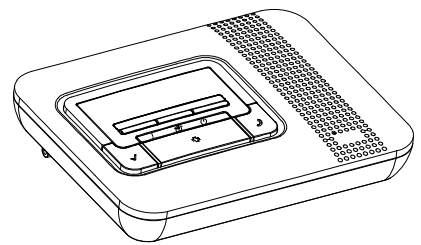

AMBER SELECT / AMBER SELECT^X

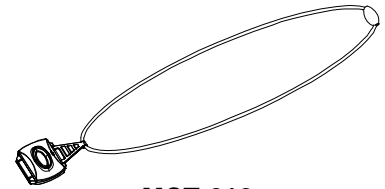

MCT-212

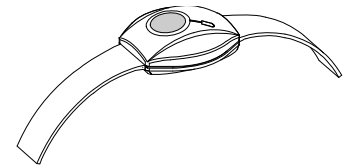

MCT-211

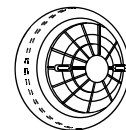

MCT-425

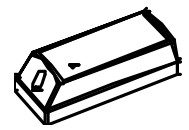

MCT-550



MCT-440/441



MCT-442



MCT-241MD

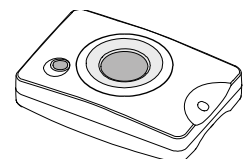

MCT-201 WP



NEXT K9-85

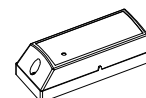

MCT-302

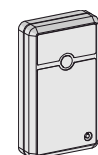

MCX-600

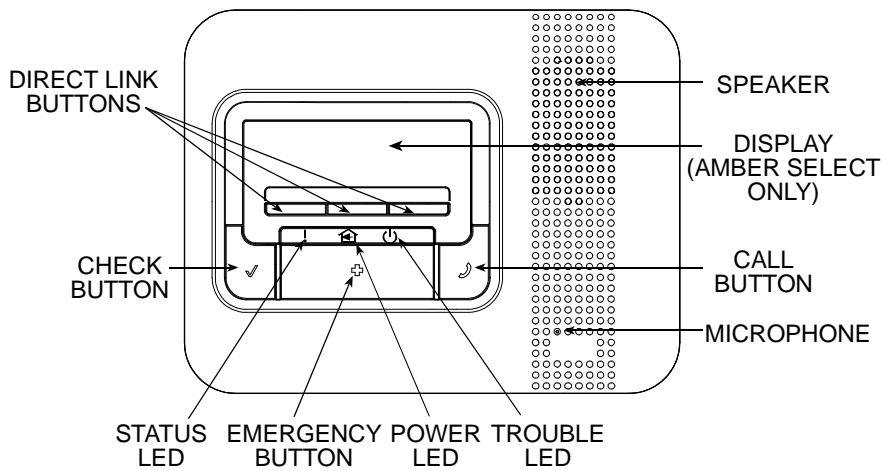

Figure 1 – Front View

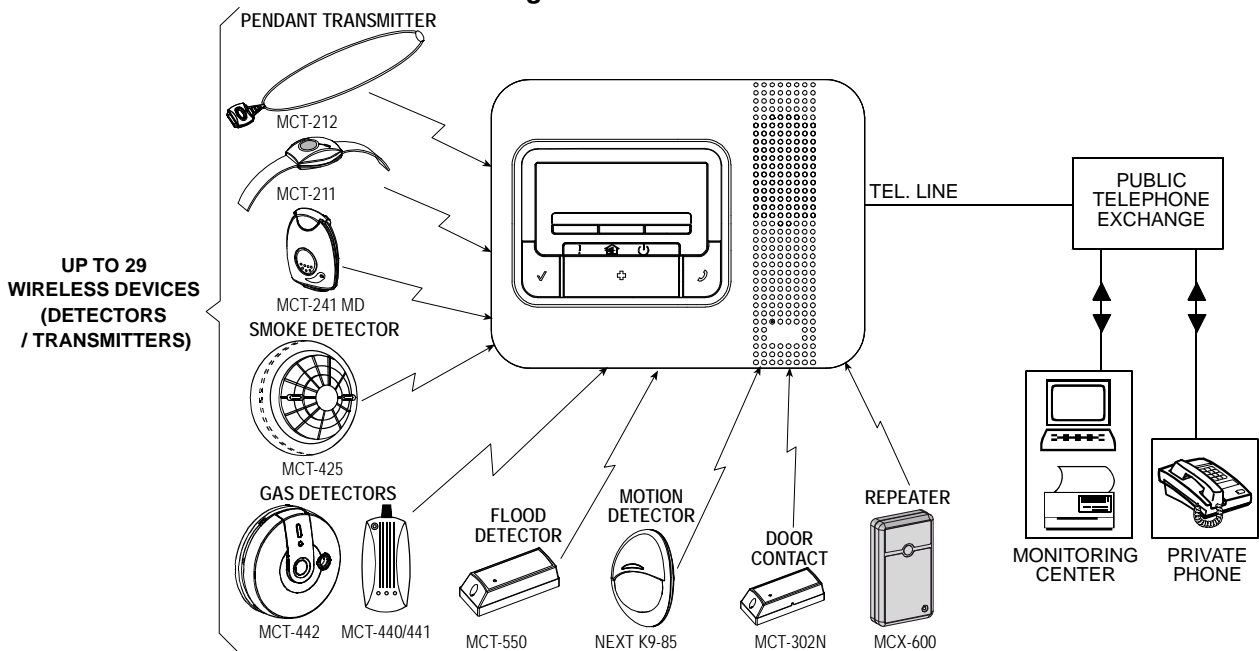

Figure 2 – System Configuration

SPECIFICATIONS

General Data

Transmitter Battery Life: 3 years (for typical use)

Frequency (MHz): 315, 433.92, 868.95, 869.2125, 869.2375 or according to local requirements.

Display: Dual line, backlit 16-character display (AMBER SELECT only) with 3 LED indicators.

Supply Voltage: 12 VAC, 1 A (via 120VAC/60Hz transformer)

Battery Pack: NI-MH 9.6 V, 1.8 Ah, type GP 0-9912-G.

LEDs:

POWER (Green): Normally ON, indicating that your system is properly connected to the power outlet.

TROUBLE (Red): Normally OFF. If LED flashes, there is a problem with the AMBER SELECT / AMBER SELECT^x or one of the devices (described on the display of AMBER SELECT).

STATUS (Yellow): Normally OFF, which indicates the system is in HOME mode. FLASHES when unit is in AWAY mode.

Special Functions:

- Calling for help by using an emergency pendant transmitter
- Speakerphone (hands-free) when communicating with Monitoring Center or when answering an incoming call by pressing the pendant
- The system supports up to 29 users (pendant transmitters and smoke detectors).
- Two-way voice communication
- Computer control and data download/upload
- Remote control by telephone
- Remote diagnostic and event log
- Visual and audible announcements

Physical Properties

Operating Temperature: 32°F to 104°F (0°C to 40°C)

Storage Temperature: -4°F to 140°F (-20°C to 60°C)

Size: 9-13/16 x 7-1/4 x 2-5/16 in. (248 x 185 x 55 mm).

Weight: 3 lb (1.35 kg)

Color: Off-white

Note: The product supports all standard monitoring center receivers such as Osborne-Hoffman.

SYSTEM SETUP

To set up your system, follow the steps below. After you complete steps 1 through 5, your system will automatically call the Monitoring Center to guide you through the rest of the set up.

Step 1

Select Unit Location

If possible, select a central location in your home for the Unit. This location should be in the area where you spend most of your time. The location should also enable an optimal signal reception for pendants and smoke detectors.

The Unit can be placed on a table, desk, or counter. It also can be mounted on a wall.

Make sure that the location you have selected is near an electrical outlet and a phone jack.

Note: Certain remote areas of your residence may lie outside the reception range of the AMBER SELECT / AMBER SELECT^X, resulting in the unit not being able to receive transmissions directly. In this case, a Repeater (MCX-600) can be used to increase the AMBER SELECT / AMBER SELECT^X reception range.

For further details, please contact the company from where the products were purchased.

Step 2

Connect the Unit to your Telephone Line (Figures 3a and 3b)*

The AMBER SELECT / AMBER SELECT^X communicates with your Monitoring Center through your telephone line.

1. Locate the phone jack on your wall where you want to connect your AMBER SELECT / AMBER SELECT^X. If a phone is already plugged into that jack, unplug it and connect it to the "PHONE" connector on the back of the AMBER SELECT / AMBER SELECT^X. Your telephone will still function normally.
2. Connect the wide end (RJ-45) of the phone cord to the "Wall Jack" on your AMBER SELECT / AMBER SELECT^X. Plug the narrow end (RJ-11) of that phone cord into the phone jack on your wall. The AMBER SELECT / AMBER SELECT^X is now connected to your telephone line.

Note: Be aware of other phone line services such as DSL. If DSL service is present on the phone line, you must install a filter. See Figure 3 for proper installation.

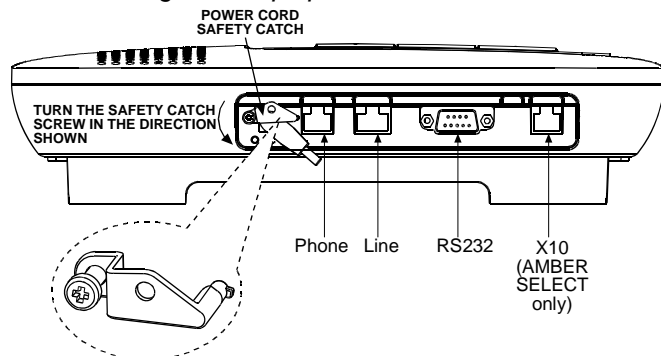

Figure 3a

Note: The safety catch is optional, can be purchased upon request.

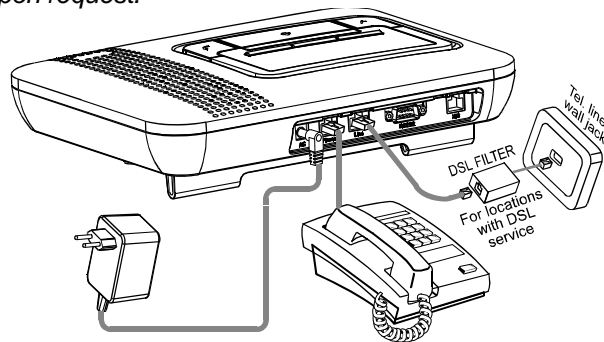

Figure 3b - Power, Telephone and Tel. line Connection

Step 3

Connect Power to AMBER SELECT / AMBER SELECT^X (Fig. 3)

During normal operation, your AMBER SELECT / AMBER SELECT^X runs on electrical power.

1. Insert the plug on the power cord into the "AC" connector on the AMBER SELECT / AMBER SELECT^X.
2. Insert the safety catch tab horizontally into the hole to the right of the power cord plug, as shown in Figure 3a.
3. Turn the safety catch screw, observing the polarity of the arrow in Figure 3a, until facing the other hole. Then secure the screw.
4. Connect the AC/AC adapter into a nearby electrical outlet. DO NOT USE AN OUTLET CONTROLLED BY A WALL SWITCH.

When the panel is not installed all three LEDs light (AMBER SELECT^X) to indicate this status. Audio prompts announce AC, Telco, or battery problem, in the event of such a problem.

Caution: When the plug is removed the unit is disconnected from the mains supply and will run on the battery pack for a period of up to 24 hours or until the plug is reconnected.

When electrical power is supplied to the AMBER SELECT^X, the green light on the front panel illuminates.

Step 4

The Unit is now connecting you to the Monitoring Center

After installation, a Monitoring Center representative will begin speaking to you.

When your Monitoring Center representative answers, you can hear them talking to you through the Unit. You can talk to the representative by speaking out loud. You do not need to use the phone.

The Monitoring Center representative will guide you through the rest of the system setup.

* For advanced phone connections see last page.

MOUNTING THE UNIT

The Unit can be located on a table, or on a wall. In both cases the Unit should be near an electrical outlet and phone line.

Mounting on a Table (Fig. 4)

Insert the AMBER SELECT / AMBER SELECT^X stand into the holes (see illustration below) and place the AMBER SELECT / AMBER SELECT^X on a table.

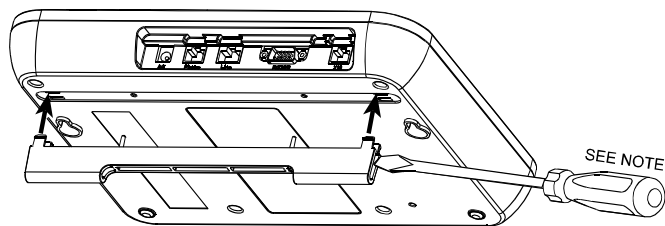

Figure 4 – Table Stand Mounting

Note: The table stand can be easily disassembled by inserting a screwdriver into the rib space of the stand and with the screwdriver pulling the stand away from the unit.

Mounting on the Wall

Drill 2 holes in the mounting wall and insert wall anchors.

Insert 2 screws in the wall (leave a 5 mm or 0.2 inch gap between the screw heads and the wall).

Mount the AMBER SELECT / AMBER SELECT^X on the screws as shown in the illustration.

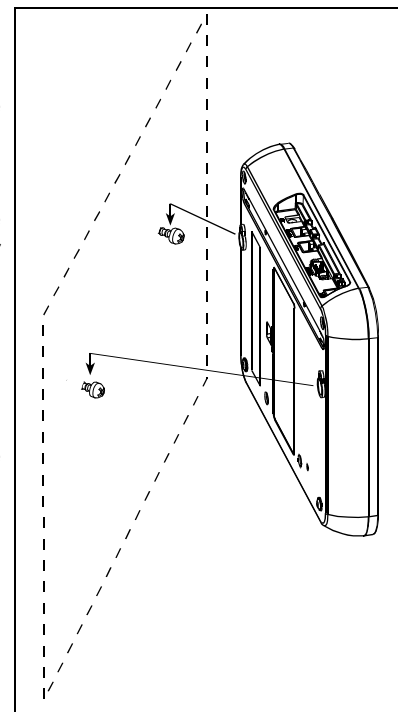

Figure 5 - Wall Mounting

USING YOUR SYSTEM

Using your AMBER SELECT / AMBER SELECT^X

Your AMBER SELECT / AMBER SELECT^X is the communication center of your system. When your pendant transmitter or optional fall-detector/smoke detector signals the AMBER SELECT / AMBER SELECT^X, the AMBER SELECT / AMBER SELECT^X contacts your Monitoring Center or private phones to report the emergency event.

Your AMBER SELECT / AMBER SELECT^X includes the following buttons.

- **EMERGENCY** (☒) – When pressed, an emergency alarm is reported to the Monitoring Center or to private phones and a two-way voice communication is opened between the unit and the Monitoring Center.
- **CALL** (☎) – When pressed, a non-emergency message is reported to the Monitoring Center and a two-way voice communication is opened between the unit and the Monitoring Center.
- **CHECK** (✓) – This button should be pressed to:
 - Answer Incoming Calls. When the phone rings, pressing this button activates the speaker phone. Alternatively, press your emergency pendant button once during an incoming call.
 - Acknowledge Programmed Reminders, such as confirming you have taken medication.
 - Change the status of the unit to HOME or AWAY. To do this, press this button continuously for 5 seconds.
 - Announce Time – press this button for 1 second.
 - Arm or disarm the alarm system.

- A. To do so, press and hold the CHECK button for 3 seconds (only when Intrusion mode is enabled).
 - B. Press the button on the arm/disarm transmitter (MCT201WP).
- **Direct Link (Speed Dial)** – The AMBER SELECT / AMBER SELECT^X includes 3 buttons for unique direct link.

Using your Pendant Transmitter

The pendant transmitter can be used to initiate an emergency call and also to answer incoming calls.

- **Pendant Activation** - Your pendant transmitter lets you signal to the AMBER SELECT / AMBER SELECT^X from anywhere in your home when you need emergency assistance. You should wear your pendant transmitter whenever you are at home even in the shower or bath. Your pendant transmitter is waterproof.

Your pendant transmitter can be activated by simply pushing its red button. Once pushed, a signal is sent from the pendant transmitter to the AMBER SELECT / AMBER SELECT^X and the red LED on the pendant transmitter illuminates. The AMBER SELECT / AMBER SELECT^X then calls the Monitoring Center or a private phone and opens a two-way voice communication between the user and the Monitoring Center or the private phone.

If your phone is ringing, pressing the pendant's red button once will answer the incoming call. You can then talk over the unit's speakerphone. To end the speakerphone call and hang up, simply press the pendant button again.

- **Neckband** - You can wear the pendant transmitter using the neckband. Slip the tab on the neckband into the slot on the pendant transmitter and fasten the tab.
- **Optional Wristband** - Your pendant transmitter can also be used with an optional wristband. To make the pendant transmitter wristband smaller, slide the pendant transmitter towards the buckle. To make the wristband larger, slide the pendant transmitter away from the buckle.

Calling for Emergency Assistance

If you need emergency assistance, press the button on your pendant transmitter or press the large, red EMERGENCY button (☒) on your AMBER SELECT / AMBER SELECT^X.

If you press the EMERGENCY button (☒) on the AMBER SELECT / AMBER SELECT^X, the display (AMBER SELECT only) shows EMERGENCY BUTTON WAS PRESSED.

The AMBER SELECT / AMBER SELECT^X calls your Monitoring Center or a private phone and sends an emergency alarm. When your Monitoring Center representative or the person on the private phone answers, you can hear them talking to you through the AMBER SELECT / AMBER SELECT^X.

If you have a phone connected to the AMBER SELECT / AMBER SELECT^X and want to use the phone to talk with the representative, let the representative know and the Monitoring Center will return your call.

Trouble

Trouble conditions are indicated by the flashing trouble LED (!) and by the sounding of beeps, and are immediately reported to the Monitoring Center.

LED	Definition
Green (power) On Flashes	AC power and battery power OK AC or battery problem detected
Yellow Off On Flashes	Away mode Home mode Active reminder

Trouble messages are shown on the unit's display (AMBER SELECT only) until they are resolved. Pressing the CHECK button (✓) confirms the trouble condition and cancels the beeps.

The AMBER SELECT / AMBER SELECT^X continues to transmit trouble messages every eight hours until the problem is resolved.

Changing System Status

When the user wants to leave the premises, the unit status must be changed to AWAY mode. The CHECK button (✓) should be held down for 5 seconds (3 seconds in Intrusion mode). The unit announces and displays (AMBER SELECT only) AWAY – REMINDERS OFF. In this state no medication reminders and no pendant checks will be announced. The unit's speaker is disabled and the yellow LED flashes. In addition, in AWAY mode inactivity detection is also disabled.

If the pendant transmitter button is pressed while in the AWAY mode, the unit will sound "EMERGENCY" and reports to the Monitoring Center. This initiates two-way communication through the speaker. In addition, any device that is alarmed while in AWAY mode immediately initiates a call to the Monitoring Center (as in HOME mode) and also initiates two-way communication.

To return the status to HOME mode, hold down the CHECK button (✓) for 5 seconds. The unit's speaker will announce and display (AMBER SELECT only) "HOME – REMINDERS ON". The status LED (🏠) will turn off.

Clock Adjustment / Announcement

To Set the Clock (AMBER SELECT)

1. To enter the clock adjustment mode, press the CHECK button (✓) three consecutive times.

After each press, be sure to wait for the time announcement to complete before pressing again. The top line, assigned to the Month, will begin to flash.

01/15/2004

08:25:53 PM

2. Use Direct Link buttons 1 (scrolls up) and 2 (scrolls down) to set the current field value.
3. Press Direct Link button 3 to scroll to select other fields: month, day, year, hours, minutes, and seconds.
4. Press the Check button (✓) to set a new date or time value.

Clock Announcement (AMBER SELECT^X)

Press the CHECK button to receive clock and status announcement.

Note: Clock adjustment is performed by the HHPCPC software.

Note: Press the Call (☎) button at any time to return to normal operation mode. This does not affect current time/date settings.

System Reset

To reset the system, simply insert a paperclip into the reset switch hole, on the bottom of the AMBER SELECT / AMBER SELECT^X.

Alternatively, press the 3 speed dial buttons continuously for four seconds.

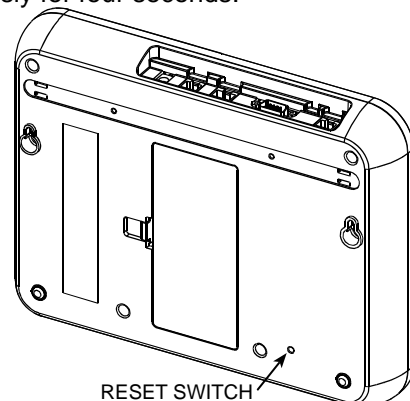

Figure 6 – Reset Switch

Direct link

The direct link buttons function as follows:

- The AMBER SELECT / AMBER SELECT^X dials the programmed telephone number stored in memory location 1, 2 or 3 and operates the unit as a speaker phone.
- Used for scrolling between fields when setting the clock.
- Used for adjusting the volume during two-way voice communication with incoming calls or for calls performed using the direct link buttons. Press direct link button 1 to increase the volume or direct link button 3 to decrease the volume.

Programming of the direct link buttons is performed by the Monitoring Center. The stored telephone numbers may be modified at any time.

In the Event of Smoke (Smoke Detector – Optional)

Your system can monitor up to 29 optional smoke detectors (purchased separately). If a smoke detector detects smoke, the smoke detector will sound its alarm and signal the AMBER SELECT / AMBER SELECT^X. The AMBER SELECT / AMBER SELECT^X calls the Monitoring Center to report a possible fire. Then the Monitoring Center representative answers, the situation is assessed, and the appropriate response is determined.

In the Event that User Falls (Fall Detector - Optional)

The fall detector is activated once the unit is tilted by more than 60° in any direction. The period of time until the fall detection is reported and the number of times that the local announcement is repeated can be programmed according to user needs.

The AMBER SELECT / AMBER SELECT^X will announce "USER HAS FALLEN".

If, during this time, the user restores the fall detector to its upright position, the unit will announce "USER IS OK".

In the Event that No Activity is detected (Motion Detector / Transmitter - Optional)

The motion detector and door contact transmitter are used to monitor the user's activity. If no activity is detected by the enrolled transmitter(s) during a pre-defined time, the AMBER SELECT / AMBER SELECT^X will report an inactivity condition to the Monitoring Center, which will initiate a two-way voice communication. Inactivity time periods are defined remotely by the central station.

Non-Emergency Services (CALL)

The Monitoring Center provides non-emergency (concierge-type) services.

When you press the CALL button (📞), the unit displays (AMBER SELECT only) CALL WAS PRESSED. If NON - EMERGENCY services are available to you, the AMBER SELECT / AMBER SELECT^X will contact the

Monitoring Center and open a two-way voice communication.

You can use the CALL button (📞) to speak to a Monitoring Center representative about your system. Because the call is non-emergency call, there might be a delay before the Monitoring Center representative responds.

As long as the display (AMBER SELECT only) shows CALL WAS PRESSED, you do not need to press the button again. A representative will begin speaking to you shortly.

Remote control by telephone Functionality

Both the central station and any person to whom the AMBER SELECT / AMBER SELECT^X unit is dialing can perform a number of actions using the AMBER SELECT / AMBER SELECT^X unit, as follows:

Pressed button	Performs
2	Acknowledge private report
9	99 sequence ends of voice session after emergency report
1	Half duplex: speaker ON, microphone OFF
3	Half duplex: microphone ON, speaker OFF
6	Automatic full duplex
4	Increase speaker volume
7	Decrease speaker volume
5	Trouble announcement
8	Trouble stop
*, #	**# sequence toggles USER TEST MODE ON/OFF
0	Not in use

Using the Amber select/ AMBER SELECT^X Intrusion Alarm System (Optional)

You can perform the following functions in the AMBER SELECT / AMBER SELECT^X alarm system:

- Arm the system in Away mode.
- Disarm the system.
- Disarm the system after alarm activation.
- View the cause of the alarm activation.

You can arm / disarm the system using either the Amber controller or a Power Code transmitter (MCT-201WP).

To arm the system by the AMBER SELECT / AMBER SELECT^X unit, press and hold the CHECK button for 3 seconds. The unit announces ARMING AWAY - PLEASE EXIT NOW and displays (AMBER SELECT only) EXIT on the screen. At the end of exit delay the unit announces AWAY, REMINDERS OFF and displays (AMBER SELECT only) AWAY on the screen, to inform you that the system is in AWAY state.

When a delay zone is entered, the unit announces PLEASE DISARM and displays (AMBER SELECT only) ENTRY on the screen. To inform you that the system is

in disarmed state (at the end of an entry delay or after pressing the button on the MCT-201WP) the unit announces HOME, REMINDERS ON and displays (AMBER SELECT only) HOME on the screen.

If any Zone in your home is opened (except the Delay Zone) during the system arming, a beep protest will sound during Exit delay time out (if enabled by the central station), and stopped if this Zone is closed.

If the Zone is still opened after the system is in Arm state, this zone will be automatically bypassed (except in the case of an EXIT/ENTRY zone) until system rearming.

Note: Reminders are active during Home mode and are disabled during Away and Exit/Entry delay mode. Entry/exit delay can be programmed by the HHPC software.

In the alarm state, the unit announces ALARM then the Amber will start its communication sequence to either private or central station telephone numbers according to pre-defined parameters.

If the Zone is still opened after the system is in Arm state, this zone is automatically bypassed until disarming and rearming of the system.

The Amber, if programmed, emits internal siren (Speaker) type sounds and announces that it is dialing the Central Station or private phones.

Disarm can be performed in one of two ways, via the remote transmitter (this can be performed outside the protected area) or press and hold the CHECK button on the unit for 3 seconds (if pre-defined when programming the unit). Reminders will be active.

TESTING PROCEDURES

The following are the necessary procedures for testing relevant system devices.

User Test Mode

There are two ways to enter User Test mode:

- During every 2-way voice communication with the monitoring center or a private phone, the AMBER SELECT / AMBER SELECT^X automatically enters User Test mode once the operator uses the telephone line.
- During a telephone conversation, the party at the other end of the telephone line must press **# in order to enter user test mode. When the call ends, the telephone line returns to normal mode.

In the USER TEST mode, the AMBER SELECT / AMBER SELECT^X announces a verbal message upon reception of a transmission from an enrolled detector.

This verbal message consists of two parts: Detector Name; and Signal Strength.

- **Detector Name** – the AMBER SELECT / AMBER SELECT^X will announce the detector type, for example, pendant, fall detector, smoke detector, and the detector's zone number.
- **Signal Strength** – 3 beeps indicate "strong" signal strength; 2 beeps indicate "good" signal strength; 1 beep indicates "poor" signal strength; no beeps indicate that the AMBER SELECT / AMBER SELECT^X has failed to measure the signal strength for that transmission.

Pendant transmitter Test

Regular manual testing of your pendant(s) is an optional feature. If your installer has enabled pendant tests, then at the scheduled time, the unit will announce and display (AMBER SELECT only) "Please Test Your Pendant". The panel will also display (AMBER SELECT only) "Press Your Pendant" along with the pendants name. You must then press the pendant transmitter, whereby the unit will announce and display (AMBER SELECT only) "Test Complete".

MAINTAINING YOUR SYSTEM

The transmitter may get dirty if touched with greasy fingers. Clean it only with a soft cloth or sponge moistened lightly with a mixture of water and mild detergent, and wipe it dry immediately.

The use of abrasives of any kind is strictly forbidden. Also never use solvents such as kerosene, acetone or thinner.

When a Pendant's Battery is Low

When a pendant transmitter's battery is low, the supervised MCT-212 flashes rapidly several times per second and the red light on the AMBER SELECT / AMBER SELECT^X flashes continuously until the pendant's battery is replaced. The display (AMBER SELECT only) shows LOW BATTERY and the pendant transmitter's name. Your system informs the Monitoring Center.

Please contact your seller for information on battery replacement.

When a Smoke Detector's Battery is Low

When a smoke detector's battery voltage is low, the smoke detector beeps every 35 seconds to alert you and will continue to beep until the detector's battery is replaced. The unit's display (AMBER SELECT only) shows LOW BATTERY and the smoke detector's name. Your system informs the Monitoring Center.

The smoke detector's batteries should last at least one year. To replace the batteries, refer to the instructions provided with the smoke detector.

TROUBLESHOOTING

The following table provides a list of problems that may arise with the system together with possible solutions.

PROBLEM	DEFINITION	SOLUTION
The red light on the AMBER SELECT / AMBER SELECT ^X is flashing and beeps are heard.	The Base Unit informs your Monitoring Center that there is a problem.	Press the CHECK button (✓) to silence the trouble beeps. Respond to the message on the unit's display (AMBER SELECT only).
The display (AMBER SELECT only) shows AC POWER FAILURE.	No electrical power is being supplied to the AMBER SELECT / AMBER SELECT ^X . The AMBER SELECT / AMBER SELECT ^X is running on backup battery power. The AMBER SELECT / AMBER SELECT ^X informs your Monitoring Center (after two min.).	Check to see if there is a power failure. If there has not been a power failure, make sure the power cord is connected securely to the AMBER SELECT / AMBER SELECT ^X and the electrical outlet.
The display (AMBER SELECT only) shows TELEPHONE LINE TROUBLE.	The unit does not detect that a working phone line is present.	Make sure the phone cord is connected securely to the AMBER SELECT / AMBER SELECT ^X and to the phone jack on the wall. If the problem persists, report the problem to your Monitoring Center.
The AMBER SELECT / AMBER SELECT ^X beeps continuously.	The AMBER SELECT / AMBER SELECT ^X is malfunctioning.	Press the CHECK button (✓) to silence the trouble beeps. Contact your Monitoring Center.
The display (AMBER SELECT only) shows AMBER SELECT / AMBER SELECT ^X LOW BATTERY.	The AMBER SELECT / AMBER SELECT ^X 's batteries are low. The AMBER SELECT / AMBER SELECT ^X informs your Monitoring Center.	Batteries will be recharged when AC power is restored.
The display (AMBER SELECT only) shows the device name and LOW BATTERY or BATTERY TROUBLE.	A pendant transmitter's or a smoke detector's battery is low. The AMBER SELECT / AMBER SELECT ^X informs your Monitoring Center.	Contact your Monitoring Center representative.
You hear strange tones when using the phone.	Your AMBER SELECT / AMBER SELECT ^X is trying to call your Monitoring Center.	Hang up so your system can report a problem to the Monitoring Center. When it finishes you can use the phone.
You hear noise interference when using your cordless phone.	The cordless phone might be picking up noise interference from the AMBER SELECT / AMBER SELECT ^X .	If the cordless phone's base is connected to the AMBER SELECT / AMBER SELECT ^X , connect the phone to a phone jack away from the AMBER SELECT / AMBER SELECT ^X . If the cordless phone's base is not connected to the AMBER SELECT / AMBER SELECT ^X , move the phone's base farther away from the AMBER SELECT / AMBER SELECT ^X .
The clock blinks continuously.	The AMBER SELECT / AMBER SELECT ^X has been reset.	Refer to the section "Clock Adjustment" (page 8).
The display (AMBER SELECT only) freezes or no response when pressing buttons.	The AMBER SELECT / AMBER SELECT ^X is jammed.	Refer to the section "System Reset" (page 8).

APPENDIX A: HOME FIRE ESCAPE PLANNING

The onset of a fire can often spread rapidly throughout your home, leaving you with little time to escape safely. Getting out of the house depends, largely, on advance warning from smoke detectors together with an advance planning strategy – namely, a home fire escape plan familiar to all members of your family and which has previously been put into practice.

Perform the following steps:

- Make preparations with members of your family to conduct an evacuation plan.
- Draw a floor plan of your home, displaying two possible exit areas of each room, including windows. Don't forget to mark the location of every installed smoke detector.
- Test all smoke detectors periodically (this must be performed in a qualified testing laboratory), to ensure their serviceability. Replace batteries as required.
- Make sure that everyone understands the escape plan and is able to recognize the sound emitted from the smoke alarm. Verify that the escape routes are clear and that doors and windows can be opened easily.
- If windows or doors in your home have security bars, make sure that the bars have quick-release mechanisms on the inside, which, in the event of an emergency, can be opened immediately. Quick release mechanisms do not compromise your security, but increase the likelihood of safely escaping a home fire.
- Practice the escape plan at least twice a year. It is important that all members of the family participate, especially children and grandparents. Allow children to master the fire escape planning procedure before holding a fire drill at night while they are asleep. The objective here is to perform a fire drill, and not to frighten the children, so informing the children of the fire drill before they go to bed can be as effective as a surprise drill. If children or others do not awaken promptly to the sound of the smoke alarm, or if there are infants or family members with mobility disabilities, make sure that someone is assigned to assist them in the fire drill and in the event of a real-life emergency.
- Agree on an outside meeting place where everyone can meet once safely out of the house premises. Remember to get out of the house first, and then to call for help. Never go back inside the house until authorized by the fire department.
- Ensure that all members of the family memorize the emergency phone number of the fire department. This will allow a member of the household to call for help from a cellular phone or from a neighbor's home.
- Be fully prepared for a real fire: when a smoke alarm sounds, get out of the house immediately and do not return to the house until authorized to do so by the fire department!
- If you live in an apartment building, make sure that you are familiar with the building evacuation plan. In the event of a fire, use the stairs, never the elevator.

Inform guests or visitors to your home about your family's fire escape plan. When visiting other homes, ask the occupants about their escape plan, if they have one. If they do not, point out the importance of such a plan and offer to help them prepare one. This is particularly important when children attend "sleepovers" at friends' homes.

Warning

Owners Instructions Notice: Smoke detectors shall not be removed by anyone except by occupants.

APPENDIX B: CONTACT ID EVENT CODES

Code	Definition
101	PERSONAL EMERGENCY
102	FAIL TO REPORT WAKEUP
103	FAIL TO REPORT WELLNESS CHECK
104	FAIL TO REPORT HEALTH TEST
105	FAIL TO REPORT MEDICATION
106	NON EMERGENCY
110	FIRE ALARM
122	SILENT ALARM
131	PERIMETER ALARM
132	INTERIOR ALARM
134	ENTRY EXIT ALARM
151	GAS DETECTED
154	WATER FLOW ALARM
301	AC LOSS
302	LOW SYSTEM BATTERY
305	SYSTEM RESET
308	SYSTEM SHUTDOWN
309	BATTERY TEST FAIL

Code	Definition
311	BATTERY DEAD
350	COM TROUBLE
351	TELCO FAULT
380	SENSOR TRBL
381	LOSS OF RF SUPERVISION
383	SENSOR TAMPER
384	RF LOW BATTERY
401	HOME AWAY
412	SUCCESS DOWNLOAD
456	FORCE ARM
602	PERIODIC TEST REPORT
606	LISTEN IN TO FOLLOW
608	PERIODIC TEST SYS TBL PRESENT
611	POINT TESTED OK
612	POINT NOT TESTED
616	SENIOR WATCH TROUBLE
626	SERVICE REQUEST
641	TIME/DATE INACCURATE

COMPLIANCE

§ 15.19(a)(3)

AMBER SELECT / AMBER SELECT^X
This device complies with Part 15 of the FCC Rules.
Operation is subject to the following two conditions:
(1) This device may not cause harmful interference, and
(2) this device must accept any interference received,

§ 15.21

Statement

Changes or modifications to this equipment not expressly approved by the party responsible for compliance could void the user's authority to operate the equipment.

5. For a Class B digital device the instructions furnished the user shall include the following or similar statement, placed in a prominent location in the text of the user or instruction manual:

§ 15.105

Statement

NOTE: This equipment has been tested and found to comply with the limits for a Class B digital device, pursuant to part 15 of the FCC Rules. These limits are designed to provide reasonable protection against harmful interference in a residential installation. This equipment generates, uses and can radiate radio frequency energy and, if not installed and used in accordance with the instructions, may cause harmful interference to radio communications. However, there is no guarantee that interference will not occur in a particular installation. If this equipment does cause harmful interference to radio or television reception, which can be determined by turning the equipment off and on, the user is encouraged to try to correct the interference by one or more of the following measures:

- Reorient or relocate the receiving antenna.
- Increase the separation between the equipment and receiver.
- Connect the equipment into an outlet on a circuit different from that to which the receiver is connected.
- Consult the dealer or an experienced radio/TV technician for help.

Due to FCC requirements in the U.S.A. and IC in Canada, transmission power is limited. This limited power output should provide a maximum operating range of 400 feet in "open space". This range may be reduced further when operating within buildings, or around other obstructions to R.F. signals. Other operating frequencies as approved for use in other parts of the world have a higher allowed transmission power which can result in greater range.

CUSTOMER PREMISES EQUIPMENT AND WIRING

The REN is used to determine the number of devices that may be connected to a telephone line. Excessive RENs on a telephone line may result in the devices not ringing in response to an incoming call. In most but not all areas, the sum of RENs should not exceed five. To be certain of the number of devices that may be connected to a line, as determined by the total RENs, contact the local telephone company. The REN of an alarm system is part of the product identifier that has the format US:VSOAL00BAMBER SELECT / AMBER SELECT^X.

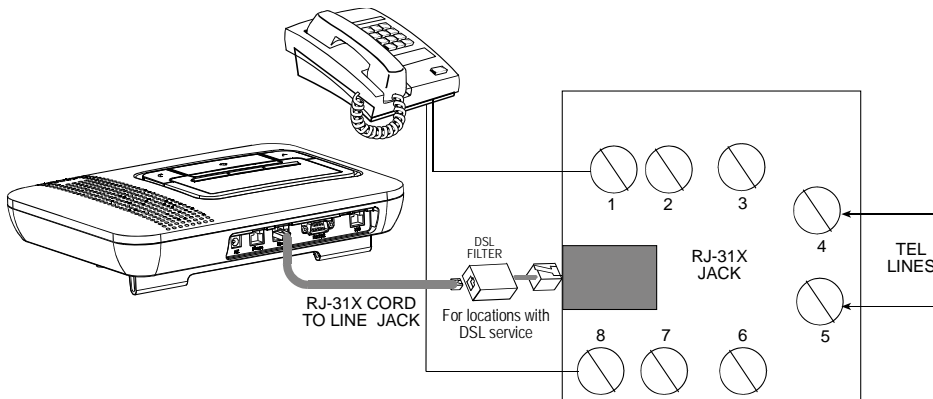

Note: For whole house line seizure with DSL service present on the phone line, you must install a filter. It is suggested to use the DSL alarm filter model Z-A431PJ31X manufactured by Excelsus Technologies, or equivalent. This filter simply plugs into the RJ-31X jack and allows alarm reporting without breaking the internet connection.

Customer Information

The required customer information is provided in the User Guide (manual).

1. This equipment, wireless emergency response system, model "AMBER SELECT / AMBER SELECT^X", complies with Part 68 of the FCC Rules and the requirements adopted by the ACTA. On the bottom panel of this equipment is a label, that contains among other information, a product identifier in the format US:VSOAL00BAMBERNA. If requested, this number must be provided to the telephone company.

2. This equipment is designed to be connected to the telephone network using RJ11 connector which complies with Part 68 rules and requirements adopted by ACTA and properly installed RJ31X connector. See Installation Instructions for details.
3. If the "AMBER SELECT / AMBER SELECT^x" causes harm to the telephone network, the telephone company will notify you in advance that temporary discontinuance of service may be required. If advance notice is not practical, you will be notified as soon as possible. Also, you will be advised of your right to file a complaint with the FCC if it is necessary.
4. The telephone company may make changes in its facilities, equipment, operations or procedures that could affect the operation of the equipment. If this happens the telephone company will provide advance notice in order for you to make necessary modifications to maintain uninterrupted service.
5. If trouble is experienced with the "AMBER SELECT / AMBER SELECT^x", for repair or warranty information please contact Visonic Inc USA., 65 West Dudley Town Road, Bloomfield, CT 06002, phone number: 8 602 430 833, URL: www.visonic.com. If the equipment is causing harm to the telephone network, the telephone company may request to disconnect the equipment until the problem is resolved.
6. The "AMBER SELECT / AMBER SELECT^x" installation is described in the User Guide. Connection to telephone company provided coin service is prohibited. Connection to party lines service is subject to state tariffs.
7. Wireless emergency response system must be able to seize the telephone line and place a call in an emergency situation. It must be able to do this even if other equipment (telephone, answering system, computer modem, etc.) already has the telephone line in use. To do so, "AMBER SELECT / AMBER SELECT^x" must be connected to a properly installed RJ31X jack that is electrically in series with and ahead of all other equipment attached to the same telephone line. Proper installation is depicted in the figure below. If you have any questions concerning these instructions, you should consult your telephone company or a qualified installer about installing the RJ31X jack and "AMBER SELECT / AMBER SELECT^x" for you.

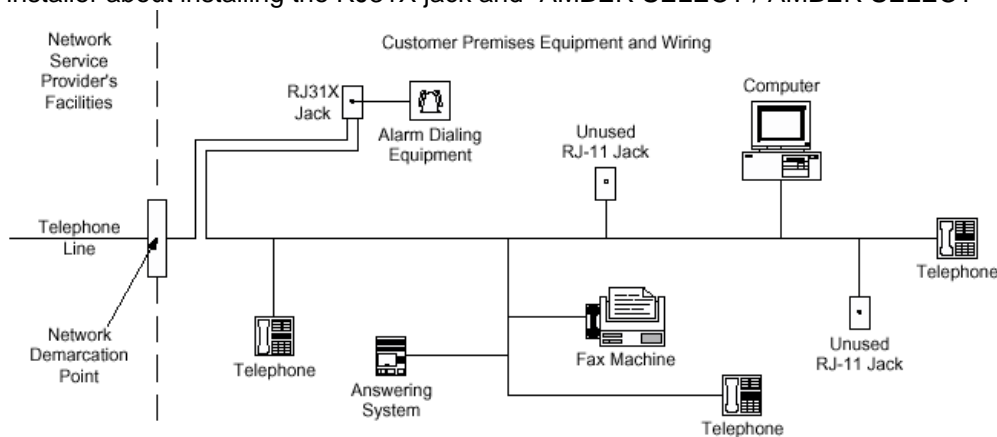

WARRANTY

Visonic Limited (the "Manufacturer") warrants this product only (the "Product") to the original purchaser only (the "Purchaser") against defective workmanship and materials under normal use of the Product for a period of twelve (12) months from the date of shipment by the Manufacturer.

This Warranty is absolutely conditional upon the Product having been properly installed, maintained and operated under conditions of normal use in accordance with the Manufacturers recommended installation and operation instructions. Products which have become defective for any other reason, according to the Manufacturers discretion, such as improper installation, failure to follow recommended installation and operational instructions, neglect, willful damage, misuse or vandalism, accidental damage, alteration or tampering, or repair by anyone other than the manufacturer, are not covered by this Warranty.

The Manufacturer does not represent that this Product may not be compromised and/or circumvented or that the Product will prevent any death and/or personal injury and/or damage to property resulting from burglary, robbery, fire or otherwise, or that the Product will in all cases provide adequate warning or protection. The Product, properly installed and maintained, only reduces the risk of such events without warning and it is not a guarantee of insurance that such events will not occur.

THIS WARRANTY IS EXCLUSIVE AND EXPRESSLY IN LIEU OF ALL OTHER WARRANTIES, OBLIGATIONS OR LIABILITIES, WHETHER WRITTEN, ORAL, EXPRESS OR IMPLIED, INCLUDING ANY WARRANTY OF MERCHANTABILITY OR FITNESS FOR A PARTICULAR PURPOSE, OR OTHERWISE. IN NO CASE SHALL THE MANUFACTURER BE LIABLE TO ANYONE FOR ANY CONSEQUENTIAL OR INCIDENTAL DAMAGES FOR BREACH OF THIS WARRANTY OR ANY OTHER WARRANTIES WHATSOEVER, AS AFORESAID.

THE MANUFACTURER SHALL IN NO EVENT BE LIABLE FOR ANY SPECIAL, INDIRECT, INCIDENTAL, CONSEQUENTIAL OR PUNITIVE DAMAGES OR FOR LOSS, DAMAGE, OR EXPENSE, INCLUDING LOSS OF USE, PROFITS, REVENUE, OR GOODWILL, DIRECTLY OR INDIRECTLY ARISING FROM PURCHASER'S USE OR INABILITY TO USE THE PRODUCT, OR FOR LOSS OR DESTRUCTION OF OTHER PROPERTY OR FROM ANY OTHER CAUSE, EVEN IF MANUFACTURER HAS BEEN ADVISED OF THE POSSIBILITY OF SUCH DAMAGE.

THE MANUFACTURER SHALL HAVE NO LIABILITY FOR ANY DEATH, PERSONAL AND/OR BODILY INJURY AND/OR DAMAGE TO PROPERTY OR OTHER LOSS WHETHER DIRECT, INDIRECT, INCIDENTAL, CONSEQUENTIAL OR OTHERWISE, BASED ON A CLAIM THAT THE PRODUCT FAILED TO FUNCTION.

However, if the Manufacturer is held liable, whether directly or indirectly, for any loss or damage arising under this limited warranty, **THE MANUFACTURER'S MAXIMUM LIABILITY (IF ANY) SHALL NOT IN ANY CASE EXCEED THE PURCHASE PRICE OF THE PRODUCT**, which shall be fixed as liquidated damages and not as a penalty, and shall be the complete and exclusive remedy against the Manufacturer.

When accepting the delivery of the Product, the Purchaser agrees to the said conditions of sale and warranty and he recognizes having been informed of.

Some jurisdictions do not allow the exclusion or limitation of incidental or consequential damages, so these limitations may not apply under certain circumstances.

The Manufacturer shall be under no liability whatsoever arising out of the corruption and/or malfunctioning of any telecommunication or electronic equipment or any programs.

The Manufacturers obligations under this Warranty are limited solely to repair and/or replace at the Manufacturer's discretion any Product or part thereof that may prove defective. Any repair and/or replacement shall not extend the original Warranty period. The Manufacturer shall not be responsible for dismantling and/or reinstallation costs. To exercise this Warranty the Product must be returned to the Manufacturer freight pre-paid and insured. All freight and insurance costs are the responsibility of the Purchaser and are not included in this Warranty.

This warranty shall not be modified, varied or extended, and the Manufacturer does not authorize any person to act on its behalf in the modification, variation or extension of this warranty. This warranty shall apply to the Product only. All products, accessories or attachments of others used in conjunction with the Product, including batteries, shall be covered solely by their own warranty, if any. The Manufacturer shall not be liable for any damage or loss whatsoever, whether directly, indirectly, incidentally, consequentially or otherwise, caused by the malfunction of the Product due to products, accessories, or attachments of others, including batteries, used in conjunction with the Products. This Warranty is exclusive to the original Purchaser and is not assignable.

This Warranty is in addition to and does not affect your legal rights. Any provision in this warranty which is contrary to the Law in the state or country where the Product is supplied shall not apply.

Warning: The user must follow the Manufacturer's installation and operational instructions including testing the Product and its whole system at least once a week and to take all necessary precautions for his/her safety and the protection of his/her property.

1/08



W.E.E.E. Product Recycling Declaration

For information regarding the recycling of this product you must contact the company from which you originally purchased it. If you are discarding this product and not returning it for repair then you must ensure that it is returned as identified by your supplier. **This product is not to be thrown away with everyday waste.**

Directive 2002/96/EC Waste Electrical and Electronic Equipment.



VISIONIC LTD. (ISRAEL): P.O.B 22020 TEL-AVIV 61220 ISRAEL. PHONE: (972-3) 645-6789, FAX: (972-3) 645-6788

VISIONIC INC. (U.S.A.): 65 WEST DUDLEY TOWN ROAD, BLOOMFIELD CT. 06002-1376. PHONE: (860) 243-0833, (800) 223-0020. FAX: (860) 242-8094

VISIONIC LTD. (UK): 7 COPPERHOUSE COURT, CALDECOTTE, MILTON KEYNES. MK7 8NL. TEL: (0870) 7300800 FAX: (0870) 7300801

INTERNET: www.visonic.com

©VISIONIC LTD. 2008 AMBER SELECT / AMBER SELECT^x USER GUIDE D-301438 (REV. 2, 09/08)



MADE IN ISRAEL